



Hawkesbury City Council

**driveway
specification/form
(july 2011)**

**for the construction of
driveway crossings**

contents include:

laybacks

driveways - concrete
- paving
- bitumen

pipe crossings

Table of Contents

Section 1	General Conditions Relevant to all Types of Driveway Crossings	3
1.1	Insurance	3
	1.1.1 Public Risk Insurance	3
1.2	Positioning of Access (Prohibited Locations).....	3
1.3	Levels and Grades	3
1.4	Public Authority/Services	3
1.5	Safety of Traffic and Pedestrians.....	3
1.6	Road Shoulder Works.....	4
1.7	Existing Footpaths.....	4
1.8	Damage to Adjoining Area	4
1.9	The Finished Surface.....	4
1.10	General Notes	4
1.11	Inspection Booking.....	5
Section 2	Specification for the Construction of a Layback Crossing	6
Section 3	Specification for the Construction of a Concrete Drive Slab	8
Section 4	Specification for the Construction of a Vehicular Crossing Using Pavers	9
Section 5	Specification for the Construction of a Sealed Bitumen Crossing	10
Section 6	Specification for the Construction of a Piped Vehicular Crossing	12

Section 1 General Conditions Relevant to all Types of Driveway Crossings

It is advised that under the provisions of the Roads Act 1993, the property owner is responsible for meeting the cost of construction, alteration and maintenance of the driveway crossing that provides entry to the land.

Special Note:

Requirement for construction in commercial and industrial areas/zones - Integral Energy requires the installation of conduits/ducts under new driveways, in accordance with Prospect Electricity drawing 049759H dated 14.7.1987. Conduit and ducting material is available from Integral Energy (Engineering Officer - Western Region (02) 4732 9685)

Approval in writing is to be submitted, indicating the completion of the laying of conduits/ducts prior to the commencement of works for the driveways.

1.1 Insurance

1.1.1 Public Risk Insurance

All contractors must carry public risk insurance with a minimum cover of \$10,000,000 (ten million dollars) and be able to show evidence of this policy before commencing work. Owners carrying out the work themselves must also carry public risk insurance for the period of the works. Owners should check their household insurance to confirm that their policy provides the same cover, and be able to show evidence of this coverage.

1.2 Positioning of Access (Prohibited Locations)

Driveway/layback crossing to be one metre clear of the side boundary line.

Driveway/layback crossing to be one metre clear of all Drainage Structures such as Kerb Lintels.

Positioning of driveway/layback at intersections to be restricted / prohibited as per Plan No. M57-5.

Driveway/layback adjacent to power poles - a minimum clearance of one metre is required between the vehicular crossing and the power pole.

1.3 Levels and Grades

Vehicular crossing to have a minimum fall of 1:48 (2%) and a maximum of 1:12 (8%) from the boundary line to the back of the layback unless otherwise directed by the Director Infrastructure Services or his Representative.

Where there is a difference between the existing level at the boundary and new work, suitable adjustment within the Owner's property will be necessary.

1.4 Public Authority/Services

It remains the Owner's/Contractor's responsibility to arrange with the relevant authority to relocate, replace or regrade any service that may affect the placing of the driveway, layback crossing/kerb and gutter reinstatement or other.

Contact "Dial Before you Dig" on 1100 for the location of all services prior to any digging.

1.5 Safety of Traffic and Pedestrians

The Owner/Contractor shall bear the responsibility of providing barricades and lights, where necessary, to ensure safe vehicular and pedestrian access around the construction/work site.

1.6 Road Shoulder Works

For works undertaken in an unsealed shoulder.

It is recommended that the road shoulder should be sealed from Edge of Seal to Edge of Gutter. It should be noted that any ongoing maintenance of this section of works is the responsibility of the property owner.

Construction can be either:

- i) Deep lift Asphaltic Concrete minimum compacted depth of 150mm using AC10, in accordance with RTA Form No. 1013 Pt K "Asphalt", or
- ii) As per Section 5 of this specification.

If directed by the Director Infrastructure Services or his Representative, the existing road shoulder and/or water table shall be regraded, reshaped and trimmed as necessary to allow for the proper control and free flow of drainage as well as for smooth transitions on the approach and departure sides of the structure.

1.7 Existing Footpaths

Where the placing of a vehicular crossing across a concrete or other sealed footpath affects the levels of foot paving, the adjacent paving is to be reconstructed to conform to the new levels to the satisfaction of the Director Infrastructure Services or his Representative, at the Owner's expense.

1.8 Damage to Adjoining Area

The Owner/Contractor shall be responsible to repair or reconstruct any areas damaged during the course of carrying out the work, and remove and dispose of all surplus material from the site to an approved tipping site.

In particular damage to road pavement or other fixed structures will require a **restoration fee** to be paid (determined from Council's fees and charges for restorations.)

1.9 The Finished Surface

Where driveways such as concrete, pavers etc are used, they shall have a non-slip finish in accordance with the following standard:

Standard: AS1141.40, .41 & .42
"Pendulum Friction Test"

Finished surfaces which cannot meet this standard must not be used.

1.10 General Notes

- (a) Formwork:

Stout boxing (forming) shall be used with the top of the form being the finished level of the concrete.

- (b) Reinforcement:

All reinforcement shall be a minimum of F72 Mesh in accordance with Australian Standard 1304 - 1991.

When lapping the reinforcing steel sheets (F72 Mesh), always ensure a minimum of one grid overlap with the steel firmly tied.

Reinforcing steel sheets (F72 Mesh) is to be supported firmly on 'bar chairs' at maximum spacing of one metre (1.0m).

(c) Concrete Strength:

Concrete to have a minimum compressive strength of 20 Megapascals (MPa) at twenty eight (28) days to Australian Standard 3600.

(d) Subgrade Material:

On a non-granular subgrade, the drive slab is to be placed on a 25mm layer of sand.

If the subgrade of the proposed crossing is considered unsatisfactory by the Director Infrastructure Services or his Representative, that material shall be removed and replaced with a minimum of 150mm of approved sandstone or road base material and compacted to the requirements of the Director Infrastructure Services or his Representative.

(e) Backfilling:

All backfilling material used is to be either top soil, sand or clean loam.

(f) Expansion Joints:

Mastic Expansion Joints must be placed at the lay-back and boundary, if any internal concrete exists, to the full depth of the slab.

(g) Protection of Works:

It remains the responsibility of the Owner/Contractor to ensure that adequate precautions are taken to protect the finished surface of the concrete during the time of curing.

(h) Stormwater Pipes:

Storm water pipes and outlets (from dwellings or otherwise) are to be relocated clear of the works and connected appropriately as approved by the Director Infrastructure Services or his Representative.

1.11 Inspection Booking

Before any construction works commence, the Owner/Contractor must complete an 'Agreement Form for Driveways' and submit, with the required fee, to Council. **Two copies** of this form are attached at the back of this document, in a tear-out format.

When booking for an inspection, quote the receipt number. A minimum of **24 hours notice** is required for all inspections such as the formwork prior to the pouring of concrete.

Contact Council's Driveway Inspector on Telephone Number (02) 4560 4444.

Section 2 Specification for the Construction of a Layback Crossing

The General Conditions in Section 1 must be read and adopted in conjunction with this section.

Where the existing kerb and gutter comprises of sandstone, written approval is required from Council's City Planning Division prior to any works commencing.

(a) Light Duty:

- i) To be constructed in Residential areas for single and duplex dwellings where kerb and gutter exists except where otherwise directed by the Director Infrastructure Services or his Representative; where kerb and gutter does not exist, a heavy duty layback is required.
- ii) Minimum length of 4.5m overall (including 0.75 wings at each end) or as per development conditions, maximum length of 6m overall, or as directed by the Director Infrastructure Services or his Representative.

Heavy Duty:

- i) To be constructed in residential areas where kerb and gutter does not exist Medium/High Density, Commercial, Rural, and Industrial areas except where otherwise directed by the Director Infrastructure Services or his Representative.
 - ii) Minimum length of 4.5m overall (including 0.75 wings at each end) or as per development conditions, maximum length of 7.5m overall or as approved by the Director Infrastructure Services or his Representative.
 - iii) A minimum of one layer of F72 mesh is to be placed in the layback generally 25mm below the finished level of the concrete surface and supported by bar chairs. Extend the layer of F72 mesh into the reinforced concrete slab in consultation with the driveway inspector. The F72 mesh is to extend into the wings of the layback.
- (b) The shape of the layback crossing is to comply with Plan No. M57-3. The Invert of the layback is to have **no lip** with the invert line to be formed with a straight edge.
- (c) Where a layback crossing exists elsewhere along the frontage of the property, that crossing must be reinstated to the kerb and gutter profile. With regards to any unused portion of the existing layback, this unused portion must be reinstated to the kerb and gutter profile. These works are to be undertaken at the full cost to the owner concerned.
- (d) Construction of kerb and gutter reinstatements is to comply with Section A - Plan No. M57-3, unless otherwise directed by the Director Infrastructure Services or his Representative.
- (e) Where a layback crossing is required in existing kerb and gutter, both the kerb and the gutter are to be removed and the layback crossing constructed.
- (f) Prior to removal of the existing kerb and gutter, saw cuts are to be made in the following locations:
- i) Through the kerb and gutter at both extremities of the proposed crossing;
 - ii) Adjacent to the edge of the gutter for the full length of the proposed crossing. This is to ensure that formwork is not required along this edge.
- (g) Where the saw cut edge adjacent to the edge of gutter is considered unsatisfactory by the Director Infrastructure Services or his Representative, formwork is to be used with a **restoration fee** to be paid (determined from Council's fees and charges for restorations) for the roadway prior to any approval being granted.

- (h) Expansion joints are to be placed at either end of the proposed layback crossing/kerb and gutter reinstatement or at a maximum spacing of 4.5m, or where otherwise directed by the Director Infrastructure Services or his Representative.
- (i) All surfaces are to be completed with a steel trowel finish, however, not to be left in a condition considered by the Director Infrastructure Services or his Representative, to be detrimental to the safety of pedestrians.
- (j) Plain concrete finish is required. Colouring or stencilling is not permitted.
- (k) In rural areas, in consultation with the driveway inspector, it is permitted to construct the layback without the wings as long as a minimum length of 4.5m is provided. Furthermore, both ends of the layback need to be thickened a further 150mm, giving a minimum thickness of 300mm at the invert, (340mm at lip, 300mm at invert and 400mm at back), for a minimum length of 300mm over the full width of 1050mm.
- (l) In areas where kerb and gutter does not exist, the invert of the gutter shall be at least 2.2m from the edge of the bitumen seal (or formed pavement) and shall be graded to conform with the grading/shape of the road pavement.
- (m) One inspection is to be carried out as follows:
 - i) When all the formwork and steel (for heavy duty) is in place.

At the time of inspection all works including any reinstatements must be ready.

If the road shoulder is to be constructed, arrangements are to be made with the Inspector for further inspections.

Section 3 Specification for the Construction of a Concrete Drive Slab

The General Conditions in Section 1 must be read and adopted in conjunction with this section.

In an area where Kerb and Gutter does not exist, a heavy duty layback shall be constructed (as per Section 2) in conjunction with these works.

(a) Light Duty:

- i) To be constructed in Residential areas for single and duplex dwellings except where otherwise directed by the Director Infrastructure Services or his Representative
- ii) A minimum 100mm thick concrete with a single layer F72 mesh to be supported by bar chairs and generally 25mm below the finished level of the concrete surface; and
- iii) A minimum width at the K&G line - 3 metres.

Heavy Duty: (Refer to the Special Note in Section 1)

- i) To be constructed in Medium/High density, Commercial and Industrial areas except where otherwise directed by the Director Infrastructure Services or his Representative;
 - ii) A minimum 150mm thick concrete with two layers of F72 mesh to be supported by bar chairs and generally 25mm below the finished level of the concrete surface and 25mm from the bottom of the concrete slab. It is permitted to extend the bottom layer of F72 into the Heavy Duty layback, in consultation with the driveway inspector; and,
 - iii) A minimum width at the K&G line - 3.0 metres.
- (b) All surfaces are to be finished to a safe standard for pedestrian traffic (refer to Section 1.9). Where a finish other than plain concrete is used, Council is **not** responsible for matching of this surface in the event of partial or total removal by Council, Public Authorities or otherwise.

Accepted Finish Types:

- i) broom finish,
- ii) coving trowel,
- iii) patterned or stamped, not to exceed 5mm in depth (must be broom finish or coving trowel),
- iv) exposed aggregate:
 - aggregate size not to exceed 14mm,
 - environmental protection measures to be undertaken to ensure only clean water enters the stormwater system,
 - upon completion of works, the table drain and downstream drainage pits to be cleaned of debris deposited during the working process.

One inspection is to be carried out as follows:

- i) When all the formwork and steel is in place.

At the time of inspection all works including any reinstatements must be ready.

Section 4 Specification for the Construction of a Vehicular Crossing Using Pavers

The General Conditions in Section 1 must be read and adopted in conjunction with this section.

In an area where Kerb and Gutter does not exist, a heavy duty layback shall be constructed (as per Section 2) in conjunction with these works.

To be constructed in Residential areas only, such as for single and duplex dwellings except where otherwise directed by the Director Infrastructure Services or his Representative.

- (a) Thickness of paver - A minimum of 60mm. Surface of pavers to be of a safe standard for pedestrian traffic. (refer to Section 1.9)
- (b) To be constructed in accordance with Council's Plan No. M57-2, and the Cement and Concrete Association of Australia "Concrete Segmental Pavements". T35, T44, T45 & T46.

- (c) Base:

Base to consist of a concrete slab (refer to Section 2 of this Specification for the construction of a concrete drive slab).

Levelling layer to consist of washed river sand to a maximum thickness of 30mm.

- (d) Edge Restraint:

The top of the pavers should be level with the top of the edge restraint or as approved by the Director Infrastructure Services or his Representative. Refer to Section A- Plan No. M57-2.

The edge restraint should have a vertical or near-vertical side on the face which abuts the segmental pavers so that the edge pavers can fit in.

A concealed edge restraint can be used to allow grass or other ground covers to abut the pavers.

Where pavers are used for the edge restraint (ie. Header course) the paver is to be bedded in a mortar bed (sand/cement mix 4:1) with the bedding to extend to the subgrade and a minimum of 150mm beyond the outer edge of this paver with the bedding to rise a minimum of one half the thickness of the paver.

Alternatively Reinforced Concrete edge beams 150mm wide, extending from the finished surface level to subgrade can be used. With this it is also possible for the base slab and edge beam to be undertaken such that the concrete base slab is extended below the edge beam for its full width. The required reinforcement for the edge beams must be in place as they will act as starter bars for the edge beam which will be poured at the conclusion of the laying of pavers (refer to Section 1.10 General Notes).

- (e) Once the crossing has been constructed, Council will not accept any responsibility for the replacement and/or the colour matching of any paving units that may be removed due to works being carried out by Council, Public Authorities, or otherwise.

If at any time the paving units subside or dislodge, Council reserves the right to have the Owner remove the effected pavers, make the effected area safe, and arrange to have the pavers replaced in a workmanlike manner.

- (f) Two inspections are to be carried out as follows:

- i) Inspection of formwork and reinforcement for concrete slab and (edge beam if applicable)
- ii) Inspection of the edge restraint/edge beam and pavers.

At the time of final inspection, all works including reinstatements must be ready.

Section 5 Specification for the Construction of a Sealed Bitumen Crossing

The General Conditions in Section 1 must be read and adopted in conjunction with this section.

In an area where Kerb and Gutter does not exist, a heavy duty layback shall be constructed (as per Section 2) in conjunction with these works.

To be constructed in rural areas.

(a) Pavement Structure

Constructed primarily in rural areas and in consultation with the driveway inspector.

Seal: 2 coat hot bitumen seal 14/10mm Aggregate

OR

1 coat hot bitumen seal (10mm) with 50mm Asphaltic Concrete wearing course

Base: 100mm Fine Crush Rock (20mm Nominal) or DGB20.

Sub Base: 200mm crushed sandstone (40mm Nominal) or DGS.

The pavement depths are only valid if the subgrade pavement materials have been compacted to the following Minimum Dry Density Ratios (AS 1289 5.4.1 - 1993)

Base course	98% Modified
Sub-base course	98% Modified
Sub grade	100% Standard

Pavement materials shall be derived from the natural disintegration of rock and shall be free from organic matter and other adverse constituents.

The Director Infrastructure Services or his Representative shall be notified of the source of supply of material, and provided with a grading chart for approval prior to the placing of the material.

All materials are to conform to RTA Form No.3051 - "Specification for Unbound and Modified Base and Sub-Base Materials for Surfaced Road Pavements".

- (b) The subgrade is to consist of sound material free from organic matter and compacted by approved mechanical means, to withstand the passing of a fully loaded 10 tonne vehicle subject to the approval of the Director Infrastructure Services or his Representative.

If the subgrade of the proposed crossing is considered unsatisfactory by the Director Infrastructure Services or his Representatives, that material shall be removed and replaced with a minimum of 200mm of approved sandstone or road base material, and compacted to the satisfaction of the Director Infrastructure Services or his Representatives.

- (c) Pavement material shall be placed in individual layers no more than 150mm or less than 75mm compacted thickness and brought to the specified moisture content and compacted with approved mechanical means to withstand the passing of a fully loaded 10 tonne vehicle subject to the approval of the Director Infrastructure Services or his Representative.
- (d) The pavement surface shall be swept by an approved brooming method, free of all dust, debris and foreign matter to a clear width of 300mm on either side of the proposed edge of bitumen seal, immediately before applying the first coat of bitumen.

The sealed surface shall have either

- i) 2 coat flush seal with Class 170 hot bitumen. The first coat shall have 14mm aggregate (1.10 litres per sqm) and the second coat 10mm aggregate (1.35 litres per sqm).

- ii) 1 coat flush seal with Class 170 hot bitumen and 10mm aggregate (1.35 litres per sqm) and wearing course to be 50mm of compacted Asphaltic Concrete (AC 10).

Sealing works to be undertaken in accordance with RTA Form Nos. 1012 Pt J and 1013 Pt K.

(e) Four inspections are to be carried out as follows:

- i) Upon the completion of the preparation of the subgrade (roller test), prior to the placing of the pavement material;
- ii) Upon the completion of the preparation of each pavement layer (roller test);
- iii) Prior to sealing., and
- iv) Upon completion of the work.

At the time of final inspection, all works including any reinstatements must be completed.

Section 6 Specification for the Construction of a Piped Vehicular Crossing

The General Conditions in Section 1 must be read and adopted in conjunction with this section.

Pipe crossings should be avoided as far as possible. However, Council will consider an application where circumstances warrant. (Refer to Plan No. M57-4)

- (a) The invert of the gutter shall be at least 2.2 metres from the edge of the bitumen seal, and shall be graded to conform with the grading/shape of the road pavement.
- (b) Pipe structure is to be a minimum diameter 375mm, headwalls at either end with Guide Posts or as determined by the Director Infrastructure Services or his Representative.
- (c) Road shoulder and table drain refer to Section 1.6 for specific details.

- (d) Pipes:

Reinforced Concrete Rubber Ring pipes only to be used and shall conform to A.S. 1342 - 'Precast Concrete Drainage Pipes' for classes X, Y & Z (2, 3 & 4). The pipes are to be of the size, class and type as approved by the Director Infrastructure Services or his Representative.

- (e) Pipe Bedding:

Bedding materials shall consist of sand and/or gravel complying with the requirements of A.S. 3725 - 'Loads on Buried Concrete Pipes'. The thickness of the bed (bedding zone) shall be 100mm for pipes up to 1500mm nominal diameter and 150mm for larger diameters. The bed material shall extend over the full width of the trench and shall be compacted by tamping, rolling and/or vibrating to a minimum relative Density of 90% or a minimum Density index of 60. Compaction to be approved by the Director Infrastructure Services or his Representative (Refer to Plan No. M57-4 for detail).

- (f) Pipe Laying:

Minimum length to be 4.88m (2 lengths of pipe) or as approved by the Director Infrastructure Services or his Representative.

Pipes shall be laid true to line, level and grade with lifting holes, if provided, to the top or in accordance with the manufacturers requirements and shall have their full length in contact with the prepared bedding as specified.

Laying shall commence at the low point of the drainage lines and proceed uphill, with the spigot end of the pipe located downstream from the socket end.

All pipes shall be jointed in accordance with the manufacturers requirements. The rubber rings for the spigot and socket pipes shall be placed in position and the spigot forced home to its full length without twisting or displacing the ring from the joint.

- (g) Backfilling:

In general, pipes shall be backfilled with compacted material conforming to the requirements of a bedding material, to a point not less than 0.3 times the diameter above the bedding (Haunch Zone). The material shall be placed over the full width of the trench either in layers not exceeding 150mm compacted thickness and compacted by conventional methods or compacted in one operation by saturation and vibration to achieve a minimum Relative Density of 90% or a minimum Density Index of 60. Compaction to be approved by the Director Infrastructure Services or his Representative.

Backfilling to a point 300mm above the pipe shall be carried out using selected material less than 75mm in size. Selected backfilling above this height shall be placed and compacted by mechanical means in layers not exceeding 150mm compacted thickness.

Driveway to be constructed above this piped crossing. Refer to the relevant section of this Specification dependant on the type of driveway to be constructed.

(h) Headwalls:

The headwalls shall be precast and either winged or flat, as approved by the driveway inspector. In the event of the minimum 2.2m from the edge of bitumen seal to the invert not being achieved, the type of headwall is to be approved by the driveway inspector prior to the works commencing.

Four inspections are to be carried out as follows:

- i) Upon the completion of the pipe bedding,
- ii) Upon the laying of the pipes, placement of the haunch zone and the installation of the head walls,
- iii) After backfilling the trench prior to the commencement of the driveway. Also any table drain adjustments that may be required,
- iv) Driveway construction. Inspections as per the relevant section of this Specification.

At the time of final inspection, all works including any reinstatements must be ready/completed.

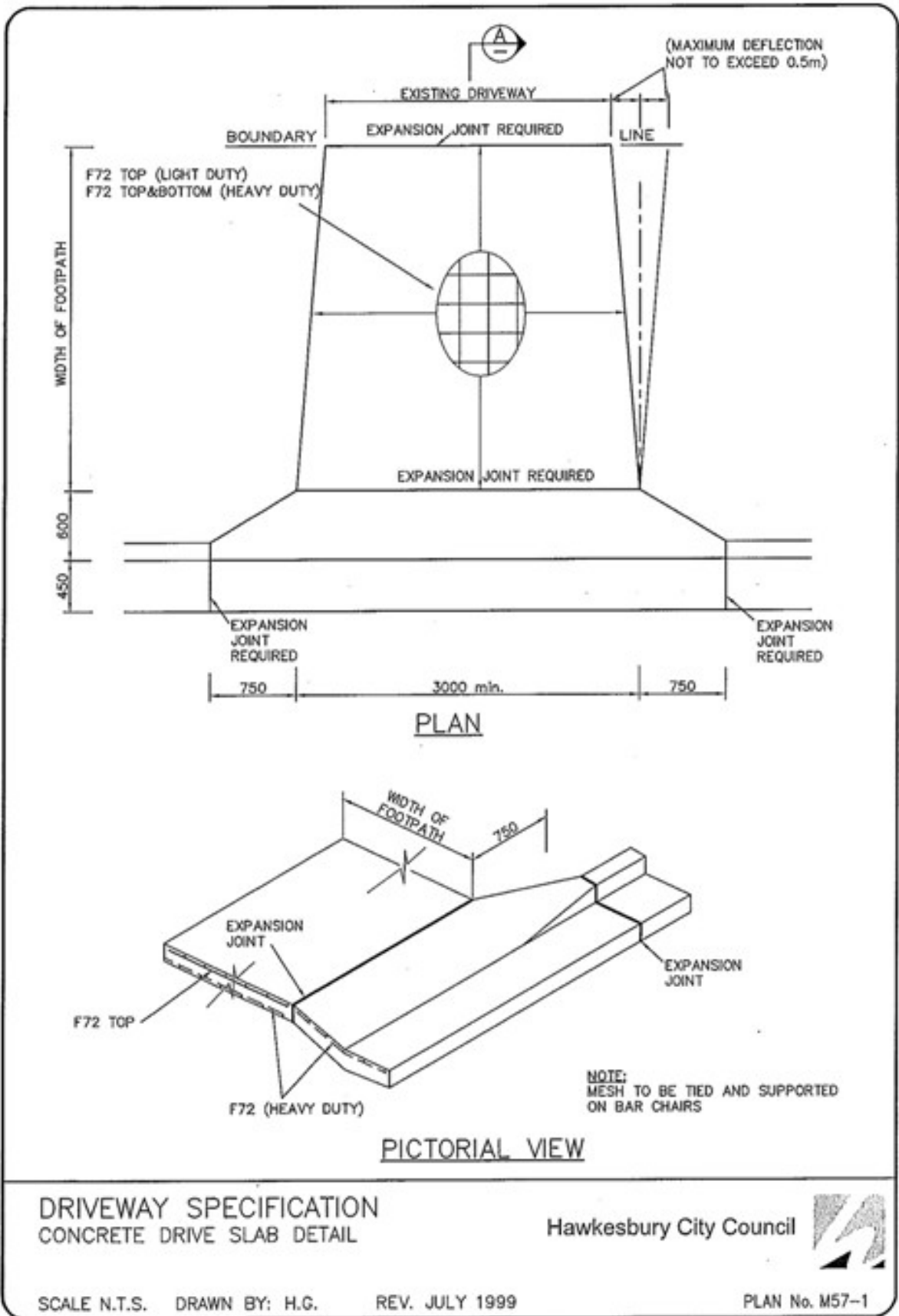

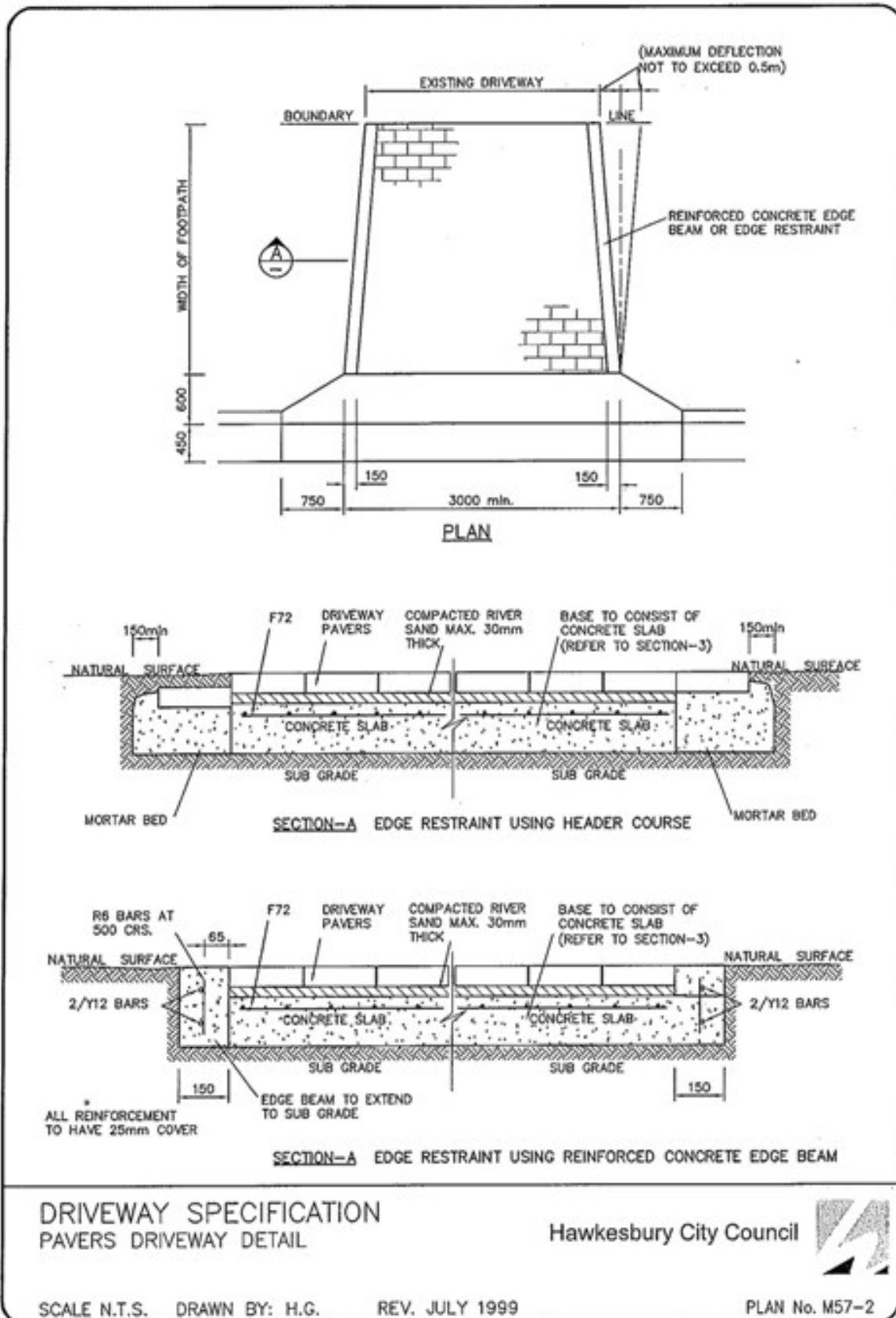

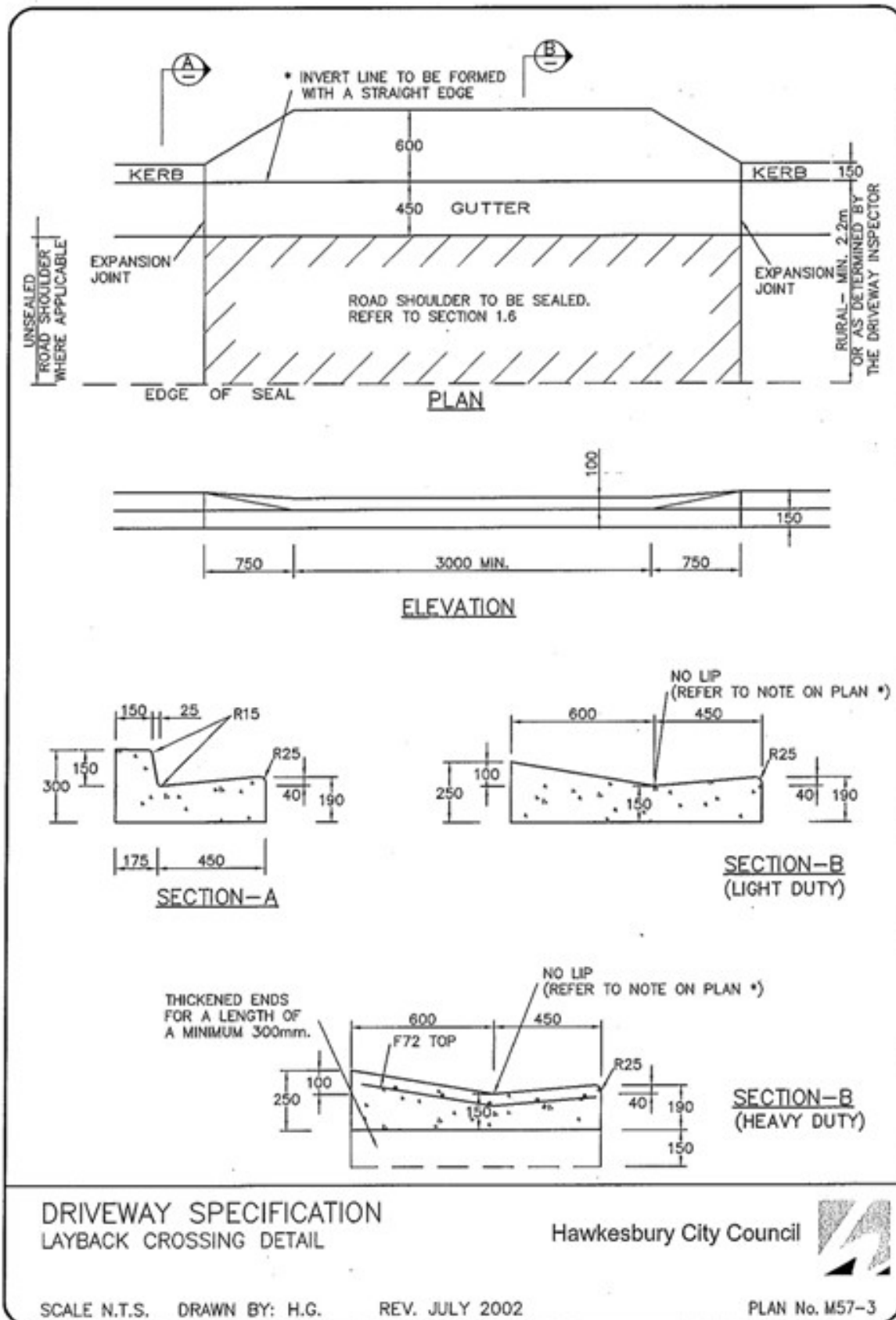

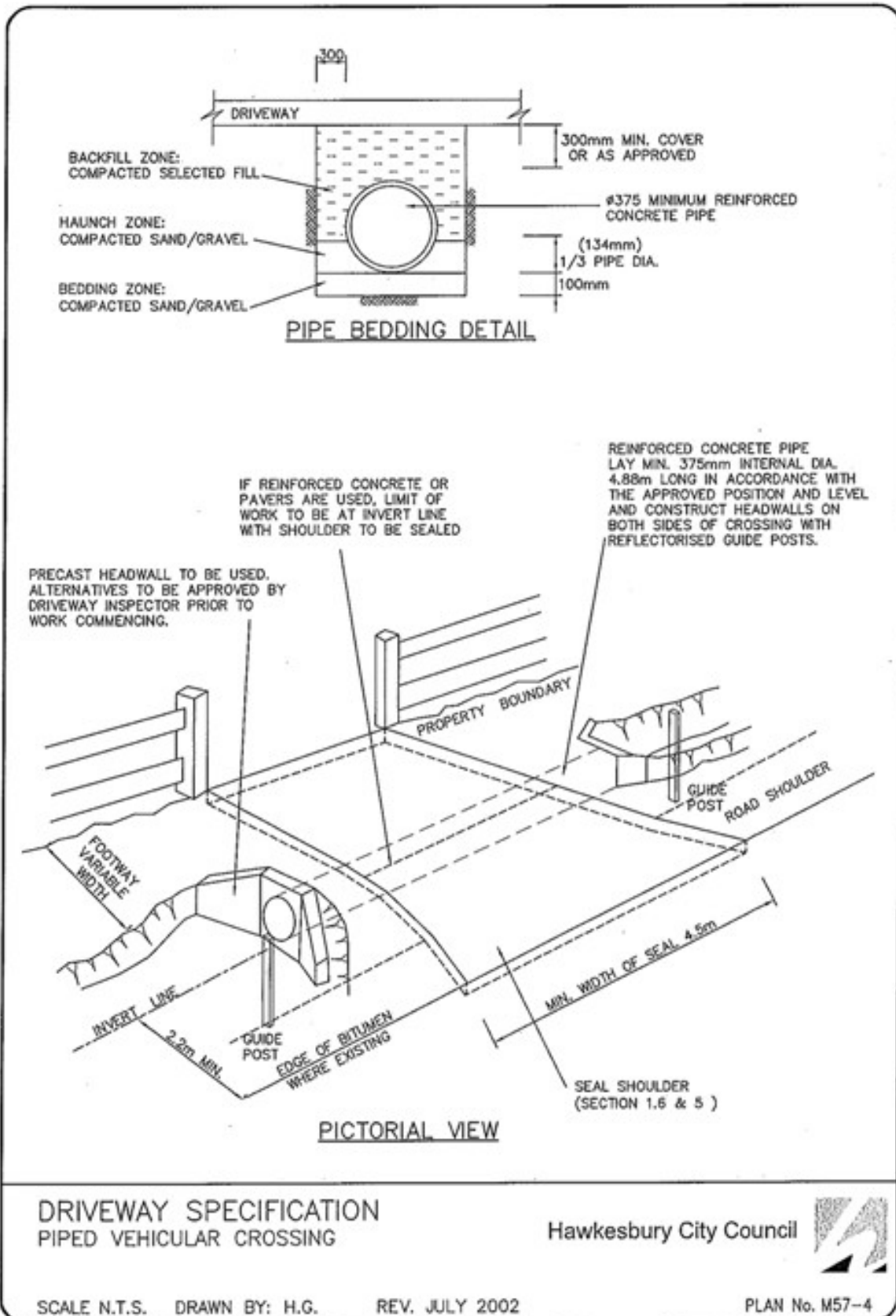

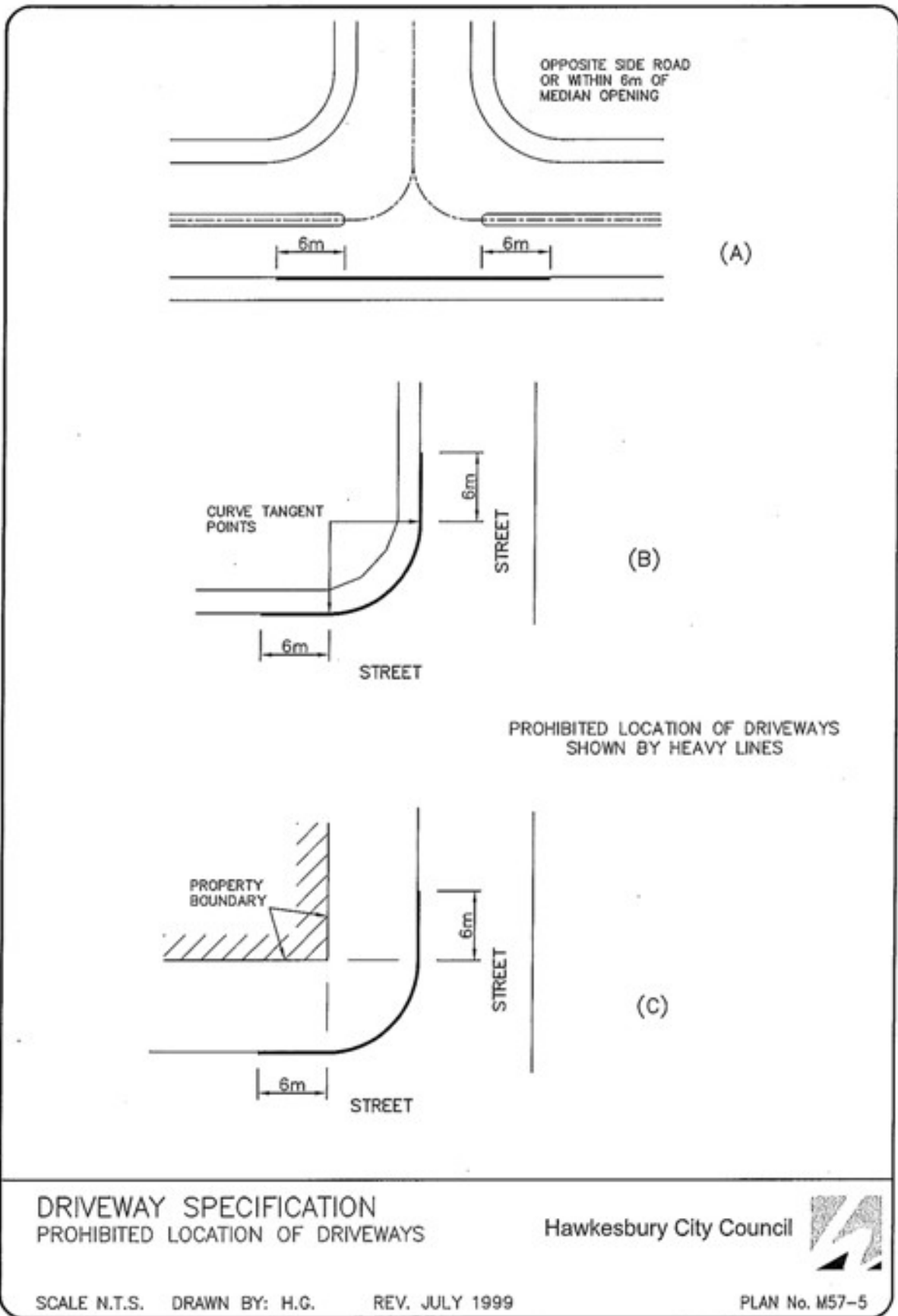

Hawkesbury City Council



366 George Street (PO Box 146) Windsor NSW 2756 DX 8601 WINDSOR
Phone: (02) 4560 4444 Facsimile: (02) 4587 7740 Email: council@hawkesbury.nsw.gov.au

agreement form for driveways

Please return form to the above address.

Office Use Only	
Receipt Details: Code 711,A/C 16319371475:	
Fee: \$118.55 (1/7/11 to 30/6/12)	

Contact Name

Phone No. Date

Locality of Works Lot No. No.

Street Town

Owner

Contractor Name

Contractor Address

Type of Work (please mark appropriate box):

- | | |
|---|---|
| <input type="checkbox"/> Concrete Drive Slab L/H Duty | <input type="checkbox"/> Pavers (residential only) |
| <input type="checkbox"/> Layback L/H Duty | <input type="checkbox"/> Piped Crossing - size: <input type="text"/> mm |
| <input type="checkbox"/> Bitumen Sealed Crossing | <input type="checkbox"/> Seal Road Shoulder |

I/we further agree to ensure that Council's requirements as listed hereunder are complied with in every respect and accept full liability to ensure that these works will be constructed in strict compliance with Council's Driveway Specification and Conditions as follows:

1. A minimum of **24 hours notice** is required for all inspections to be booked by the Owner/Contractor;
2. Should the second inspection of the formwork be rejected by non-compliance with Council's Specifications or conditions of approval, **an additional inspection fee of \$61.85 will be paid prior to each and every inspection thereafter;**
3. Pedestrians shall be permitted adequate and safe use of part of the footpath or, alternatively, a properly barricaded passage along the roadway, if required, and should be placed so as not to impede the flow of vehicular traffic;
4. Should the finish of the concrete not be of a suitable standard or any alterations be made after the formwork has been approved, I accept Council's decision to remove and replace this structure at my expense at any such time as it is deemed necessary by Council.



5. A Public Risk Liability Policy to the amount of \$10,000,000 to be obtained by the Owner/Contractor to cover all works undertaken on public property. A copy of this Policy/Receipt for the Policy is enclosed, details as below:

Insurance Company:

Policy Number: Period of Insurance Cover:

6. Is work a condition of Development or subdivision application?

No

Yes

File No.:

A cheque for \$118.55 is enclosed/has been paid (current to 30/6/2012)

(Refer to Revised Specifications 7/2002)

(All fees are GST inclusive)

Owner's Signature

Date

Privacy Notice

Council is bound by the provisions of the Privacy and Personal Information Protection Act 1998, in the collection, storage and utilisation of personal information provided in this form. Accordingly, the personal information will only be utilised for the purposes for which it has been obtained and may be available for public access and/or disclosure under various NSW Government legislation.

Hawkesbury City Council



366 George Street (PO Box 146) Windsor NSW 2756 DX 8601 WINDSOR
Phone: (02) 4560 4444 Facsimile: (02) 4587 7740 Email: council@hawkesbury.nsw.gov.au

agreement form for driveways

Please return form to the above address.

Office Use Only	
Receipt Details: Code 711,A/C 16319371475:	
Fee: \$118.55 (1/7/11 to 30/6/12)	

Contact Name

Phone No. Date

Locality of Works Lot No. No.

Street Town

Owner

Contractor Name

Contractor Address

Type of Work (please mark appropriate box):

- | | |
|---|---|
| <input type="checkbox"/> Concrete Drive Slab L/H Duty | <input type="checkbox"/> Pavers (residential only) |
| <input type="checkbox"/> Layback L/H Duty | <input type="checkbox"/> Piped Crossing - size: <input type="text"/> mm |
| <input type="checkbox"/> Bitumen Sealed Crossing | <input type="checkbox"/> Seal Road Shoulder |

I/we further agree to ensure that Council's requirements as listed hereunder are complied with in every respect and accept full liability to ensure that these works will be constructed in strict compliance with Council's Driveway Specification and Conditions as follows:

1. A minimum of **24 hours notice** is required for all inspections to be booked by the Owner/Contractor;
2. Should the second inspection of the formwork be rejected by non-compliance with Council's Specifications or conditions of approval, **an additional inspection fee of \$61.85 will be paid prior to each and every inspection thereafter;**
3. Pedestrians shall be permitted adequate and safe use of part of the footpath or, alternatively, a properly barricaded passage along the roadway, if required, and should be placed so as not to impede the flow of vehicular traffic;
4. Should the finish of the concrete not be of a suitable standard or any alterations be made after the formwork has been approved, I accept Council's decision to remove and replace this structure at my expense at any such time as it is deemed necessary by Council.



5. A Public Risk Liability Policy to the amount of \$10,000,000 to be obtained by the Owner/Contractor to cover all works undertaken on public property. A copy of this Policy/Receipt for the Policy is enclosed, details as below:

Insurance Company:

Policy Number: Period of Insurance Cover:

6. Is work a condition of Development or subdivision application?

No Yes File No.:

A cheque for \$118.55 is enclosed/has been paid (current to 30/6/2012)

(Refer to Revised Specifications 7/2002)

(All fees are GST inclusive)

Owner's Signature

Date

Privacy Notice

Council is bound by the provisions of the Privacy and Personal Information Protection Act 1998, in the collection, storage and utilisation of personal information provided in this form. Accordingly, the personal information will only be utilised for the purposes for which it has been obtained and may be available for public access and/or disclosure under various NSW Government legislation.